

DESIGN CHANGE		
ITEM	REASON OF CHANGE	DESCRIPTION

RANGE	COMMON TOLERANCE TABLE				FILE NO	REV.NO	DRAW BY	
	<A>		<C>	<D>				
< 8	±0.05	±0.1	±0.2	±0.4	PART NO	SCALE	1:1	APPROVE BY
8-25	±0.08	±0.15	±0.3	±0.5	PART NAME	UNITS	M/M	DATE
25-80	±0.12	±0.25	±0.5	±1.0	MODEL NO	MATERIAL		PROJECTION
80-250	±0.25	±0.4	±0.8	±1.5	PAHT			
250-800	±0.5	±0.8	±1.5	±3.0				
800-2500	±1.0	±1.5	±3.0	±6.0				
ANGULAR	±0.15°	±0.3°	±0.5°	±0.8°				



ORANGE	+3.3V	16AWG
ORANGE	+3.3V	16AWG
BLACK	GND	18AWG
RED	+5V	18AWG
BLACK	GND	18AWG
RED	+5V	18AWG
BLACK	GND	18AWG
S.GRAY	PG	22AWG
PURPLE	+5VSB	18AWG
YELLOW	+12V	18AWG
YELLOW	+12V/12V+	18AWG
ORANGE	+3.3V	16AWG

ORANGE/S.BROWN	+3.3V/3V+	16/22AWG
BLUE	-12V	18AWG
BLACK	GND	18AWG
S.GREEN	PSON	22AWG
BLACK	GND	18AWG
BLACK	GND	18AWG
BLACK	GND	18AWG
N/C	---	---
RED	+5V	18AWG
RED/S.RED	+5V/5V+	18/22AWG
RED	+5V	18AWG
BLACK	GND	18AWG

PRINTED "EPS12V"

BLACK	GND	18AWG	YELLOW	+12V	18AWG
BLACK	GND	18AWG	YELLOW	+12V	18AWG
BLACK	GND	18AWG	YELLOW	+12V	18AWG
BLACK	GND	18AWG	YELLOW	+12V	18AWG

BLACK	GND1/GND	18/22AWG	YELLOW	+12V	18AWG
BLACK	GND	18AWG	YELLOW	+12V	18AWG
BLACK	GND	18AWG	YELLOW	+12V	18AWG
BLACK	GND	18AWG	YELLOW	+12V	18AWG

YELLOW	+12V	18AWG	BLACK	GND	18AWG
YELLOW	+12V	18AWG	BLACK	GND	18AWG
YELLOW	+12V	18AWG	BLACK	GND	18AWG
BLACK	GND	18AWG	BLACK	GND	18AWG

YELLOW	+12V	18AWG	BLACK	GND	18AWG
YELLOW	+12V	18AWG	BLACK	GND	18AWG
YELLOW	+12V	18AWG	BLACK	GND	18AWG
BLACK	GND	18AWG	BLACK	GND	18AWG

Yellow	+12V	18AWG	PIN 1
Black	GND	18AWG	PIN 1
Black	GND	18AWG	PIN 1
Red	+5V	18AWG	PIN 1

Yellow	+12V	18AWG	PIN 1
Black	GND	18AWG	PIN 1
Black	GND	18AWG	PIN 1
Red	+5V	18AWG	PIN 1

YELLOW	+12V	18AWG	PIN 1
BLACK	GND	18AWG	PIN 1
BLACK	GND	18AWG	PIN 1
RED	+5V	18AWG	PIN 1

YELLOW	+12V	18AWG	PIN 1
BLACK	GND	18AWG	PIN 1
BLACK	GND	18AWG	PIN 1
RED	+5V	18AWG	PIN 1

YELLOW	+12V	22AWG	PIN 1
BLACK	GND	22AWG	PIN 1
BLACK	GND	22AWG	PIN 1
RED	+5V	22AWG	PIN 1

YELLOW	+12V	18AWG	Pin 1
BLACK	GND	18AWG	Pin 1
RED	+5V	18AWG	Pin 1
BLACK	GND	18AWG	Pin 1
ORANGE	+3.3V	18AWG	Pin 1

YELLOW	+12V	18AWG	Pin 1
BLACK	GND	18AWG	Pin 1
RED	+5V	18AWG	Pin 1
BLACK	GND	18AWG	Pin 1
ORANGE	+3.3V	18AWG	Pin 1

YELLOW	+12V	18AWG	Pin 1
BLACK	GND	18AWG	Pin 1
RED	+5V	18AWG	Pin 1
BLACK	GND	18AWG	Pin 1
ORANGE	+3.3V	18AWG	Pin 1

GREEN	SCL	24AWG	PIN 1
GRAY	SDA	24AWG	PIN 1
RED	SMBAlert	24AWG	PIN 1
BLACK	GND	24AWG	PIN 1

TTL Signal	BLACK	GND	26AWG
	ORANGE	TTL	26AWG

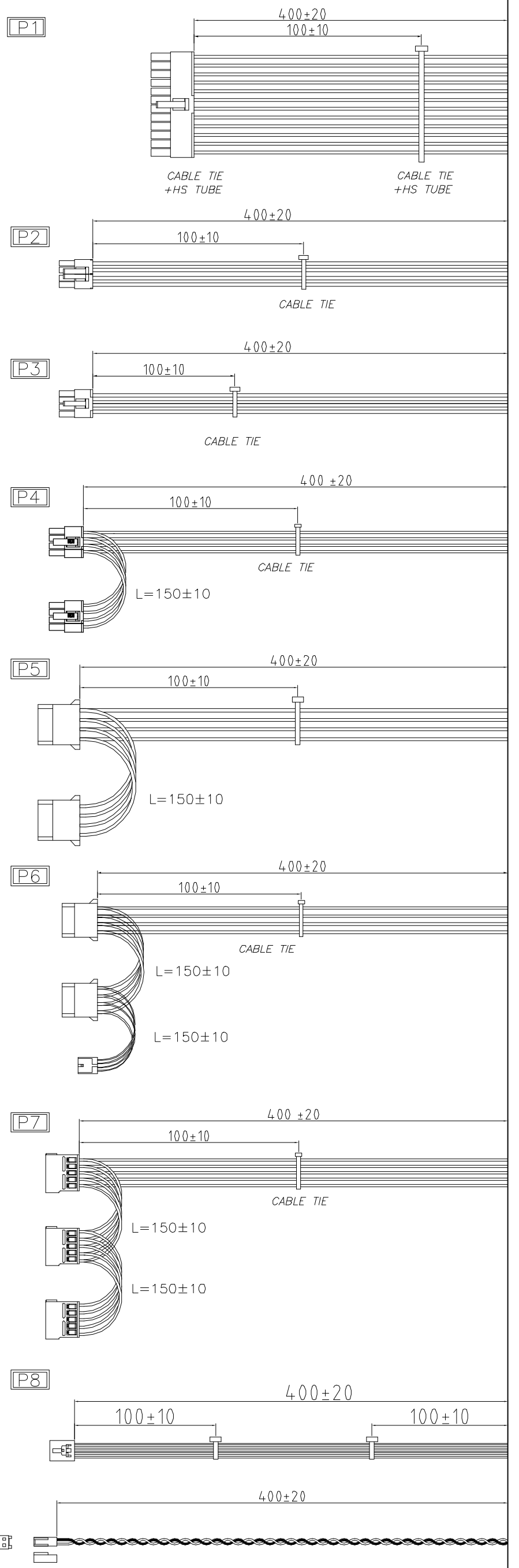

REV	DESCRIPTION	LOCATION	SIGN	DATE
A	RELEASE		Ben	2020.10.16

A2	UNIT	SCALE	SHEET	MODEL No.	IX-700RSH1UP8UC			
	MM	1,000	1 of 1	PART NAME	CABLE DEFINE			
APPROVED	CHECKED	DESIGNED	PART No.		REV	A		
2020.10.16	2020.10.16	2020.10.16						