

TC-2U50PD8G

Switching Power Supply

(2U 80 Plus Gold PSU)

SPECIFICATION

Revision: A1.2

1.0 INPUT:

1.1 VOLTAGE

RANGE	MINIMUM	NOMINAL	MAXIMUM	UNITS
1	90	115,230	264	VRMS

1.2 FREQUENCY

47Hz ~ 63Hz

1.3 CURRENT

8A/100V, 4A/240V

1.4 INRUSH CURRENT

115V/50A(max.), 230V/100A(max.) at 25°C (cold start)

1.5 POWER EFFICIENCY

At 20%/50%/100% load AC 115V 60Hz and AC 230V 50Hz Platinum(90%/92%/89%)
Gold(87%/90%/87%) Silver(85%/87%/85%) Bronze(82%/85%/82%)
Standard(80%/80%/80%)

1.6 STANDBY MODE

During measurement of the "STANDBY MODE" condition, the main converter is off (PS_ON=High). +5Vsb converter is working and standby input power is measured.

Load Condition	Efficiency	Power in
0A	----	<=0.9W
90mA	>=50%	----
250mA	>=60%	----
1.0A	>=70%	----
*2010 ErP Standby efficiency		

1.7 ACTIVE POWER FACTOR CORRECTION (PFC):

PFC at half/full load:

≥0.95 at AC 115v 60Hz(typical)

≥0.90 at AC 230v 50Hz(typical)

2.0 OUTPUT:

GROUP	1					2
	+5V	+12V1	+12V2	-12V	+3.3V	+5VSB
MAX.LOAD	20A	20A	20A	0.3A	20A	2.5A
MIN.LOAD	0A	0.5A	0A	0A	0A	0A
REGULATION	±5%	±5%	±5%	±10%	±5%	±5%
RIPPLE & NOISE (mV)	50	120	120	120	50	50
Capacitive Loads (uF)	12000	11000		350	12000	350
Dynamic Load Capacitive Load (uF)	1000	2200			1000	1

NOTE:

- The continuous maximum total output power shall not exceed 500W.
 +12V1 and +12V2 DC maximum output power shall not exceed 40A(480W).
 +3.3V and +5V DC maximum combined output power shall not exceed 100W.
- Maximum peak total DC output power should not exceed 550W.
- Peak power and current loading should be supported for a minimum of 1 second.
- Ripple and Noise measuring with an oscilloscope with 20 MHz bandwidth. Output should be bypassed at the connector with a 0.1uF ceramic disk capacitor and a 10uF electrolytic capacitor to simulate system load. The length of ground wire on probe should not longer than 40mm, if a Non - differential type of scope was used.

2.1 CROSS REGULATION

The +5V & +3.3V combined load and +12VDC load shall remain within the defined in section 2.0 over cross load combinations shown Figure 1:

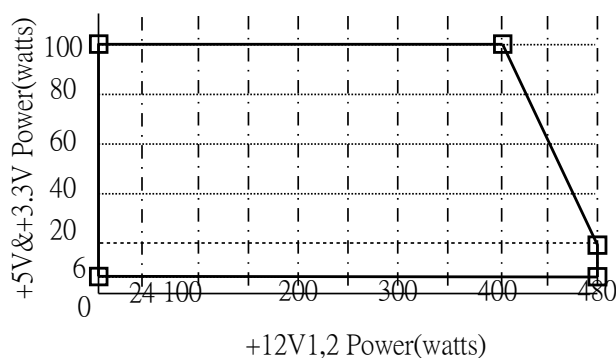

Figure 1

2.2 HOLD-UP TIME: 17ms(minimum)

Test Condition: Full load. AC input 115V or 230V, 60 Hz .

2.3 LOAD TRANSIENT RESPONSE (STEP LOAD)

Step load changes up to 65%(12V) and 30%(3.3V and 5V) of full load, while other loads remains constant within the rating. The load waveform shall be a square wave with the slope of the rise and fall at 0.5A/usec and the load transient repetition rate shall be tested between 50Hz to 5kHz at duty cycle range from 10%~90%. The DC output voltage will stay within regulation during the step load changes.

2.4 OVERSHOOT

Overshoot at turn on or turn off shall be less than 10% for 3.3V, 5V and 12V output voltage, and 15% for -12V output voltage.

2.5 TIMING, HOUSEKEEPING AND CONTROL

A low active PS-ON (DC ON/OFF) input signal is equipped, which provide the interface **ENABLE** or to **DISABLE** the **GROUP1** of DC output. This signal is electrically to interface with **TTL, OPEN COLLECTOR** and the **HARD SWITCH**.

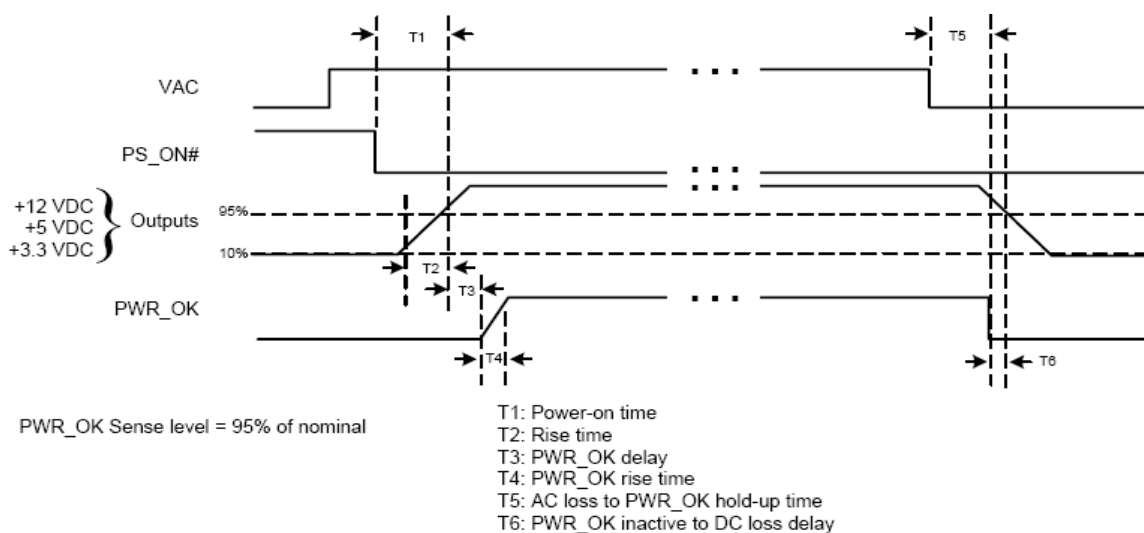

SIGNAL NAME		MAXIMUM	MINIMUM
T1	PS_Power-on time	500mS	
T2	Rise time from each main output	20mS	2mS
T3	PWR_ok delay	500mS	100mS

T4	PWR_ok rise time	10mS	
T5	AC loss to PWR_OK hold-up time		17mS
T6	PWR_OK inactive to DC loss delay		1mS
	Rise time for the 5Vsb output	20mS	1mS
	AC_+5Vsb delay	1500mS	

2.5.1 POWER GOOD SIGNAL:

Signal Type: open collector +5DC, TTL compatible.

Logic Level: <0.4V while sinking 4 mA.

Logic Level High: between 2.4VDC and +5V output while sourcing 200 uA.

Max Ripple/Noise: 400mV pk-pk. (no capacitor test)

3.0 OUTPUT PROTECTION

3.1 TOTAL POWER PROTECTION: (OPP)

Total power 150% max with shut-down and latch off protection.

3.2 OVER VOLTAGE PROTECTION: (OVP)

OVER VOLTAGE	Max.	RESULT
+3.3V	4.3V	Shut down & Latch OFF The Group 1 DC Output
+5V	7.0V	
+12V	15.6V	
+5Vsb	7.0V	

3.3 SHORT CIRCUIT PROTECTION: (SCP)

The short between any output of group 1 will shut down all group 1.

The short at group 2 will Shut down both group 1 and group 2.

3.4 OVER CURRENT PROTECTION: (OCP)

Over current protection was designed to limit the current to operate within safe operating conditions.

Total current 200% max with shut-down and latch off protection.

+12V1 and +12V2 have separate current limit protection circuits.

3.5 OVER TEMPERATURE PROTECTION: (OTP)

This power supply include an over-temperature protection sensor, which can trip and shut down the power supply at a preset temperature point. Such an overheated condition is typically the result of cooling fan failure or excessive maximum operation temperature.

3.6 NO-LOAD SITUATION

No damage or hazardous condition should occur with all the DC output connectors disconnected from the load. The power supply may latch into the shutdown state.

3.7 RESET AFTER SHUTDOWN

Whenever the power supply latches into shutdown state due to fault condition on its output, the power supply will return to normal operation only after the fault has been removed and the PS_ON# has been pulled low again. If the power supply latches into shutdown state due to fault condition on 5Vsb, the power supply will return to normal operation only after the fault has been removed and the power switch(power cord) has been cycled off/on(plugged out/in) with A MINIMUM OFF TIME OF 3 SECONDS.

4.0 COOLING OF POWER SUPPLY

A DC fan was equipped to cooling the power supply, the fan will blow air into power supply and exhaust through the vent holes in AC receptacle side. **This fan is only for power supply internal cooling purpose, not for system cooling.**

Fan parameters:

Rated Voltage	12VDC
Dimension	60*60*25(mm)
Air flow	20.51CFM min.
Noise	<24.0db(A)

5.0 ENVIRONMENT

5.1 OPERATING

AMBIENT OPERATION TEMPERATURE: 0 to 50 °C.

AMBIENT OPERATION RELATIVE HUMIDITY: 20% to 80%

5.2 SHIPPING / STORAGE

AMBIENT STORAGE TEMPERATURE:-40 to 85 Deg C

AMBIENT STORAGE RELATIVE HUMIDITY:10% to 95%

6.0 MTBF

Over 100,000 hours at 25 Deg C. excluding the DC Fan.

7.0 EMC

Comply to EN55022: 2006 +A1: 2007 Class B, EN55024: 1998 +A1: 2001 +A2: 2003,
EN61000-3-2: 2006 Class A/D, EN61000-3-3: 1995 +A1: 2001 +A2: 2005, CISPR 22: 2005 +A1:
2005 +A2: 2006, ICES-003: 2004, AS/NZS CISPR 22: 2006.

8.0 SAFETY

Confirm to IEC 60950-1: 2005, EN 60950-1/A11: 2009, UL 60950-1: 2007, CAN/CSA C22.2 No.
60950-1: 2007, CNS14336(2005), CNS13438(2006).

9.0 MECHANICAL

Dimension: W100mm x L 245mm x H 70mm, +/-1mm.