

REF. ID.	PIN NO.	SIGNAL	WIRE COLOR	GAUGE	CONNECTOR TYPE	CABLE LENGTH	
P1 /24	1	+3.3VDC	ORANGE	20	WST P20-142002K11D+ P4-142002K11D or EQUIV.	310 $\pm$ 20 mm	
	2	+3.3VDC	ORANGE	20			
	3	COM	BLACK	18			
	4	+5VDC	RED	20			
	5	COM	BLACK	18			
	6	+5VDC	RED	20			
	7	COM	BLACK	18			
	8	PW-OK	GRAY	24			
	9	+5Vsb	PURPLE	20			
	10	+12V1	YELLOW	18			
	11	+12V1	YELLOW	18			
	12	+3.3VDC	ORANGE	20			
	13	+3.3VDC	ORANGE	20			
	14	+3.3VSense	BROWN	24			
	15	-12VDC	BLUE	24			
	16	COM	BLACK	18			
	17	PS-ON#	GREEN	24			
	18	COM	BLACK	18			
	19	COM	BLACK	18			
	20						
	21	+5VDC	RED	20			
	22	+5VDC	RED	20			
	23	+5VDC	RED	20			
	24	COM	BLACK	18			
P2	1	+3.3V	ORANGE	20	MOLEX SD-67926 -0011 or EQUIV.	300 $\pm$ 20 mm	
	2	COM	BLACK	20			
	3	+5V	RED	20			
	4	COM	BLACK	20			
	5	+12V1	YELLOW	20			
P3	1	+3.3V	ORANGE	20	MOLEX SD-67582 -001 or EQUIV.	170 $\pm$ 10mm	
	2	COM	BLACK	20			
	3	+5V	RED	20			
	4	COM	BLACK	20			
	5	+12V1	YELLOW	20			
P4	1	COM	BLACK	16	MOLEX 39-01-2040 or EQUIV.	310 $\pm$ 20 mm	
	2	COM	BLACK	16			
	3	+12V2	YEL/BLK	16			
	4	+12V2	YEL/BLK	16			
P5 P7	1	+12V1	YELLOW	20	AMP 1-480424-0 or EQUIV.	310 $\pm$ 20 mm	
	2	COM	BLACK	20			
	3	COM	BLACK	20			
	4	+5V	RED	20			
P6	1	+12V1	YELLOW	20	AMP 1-480424-0 or EQUIV.	170 $\pm$ 10mm	
	2	COM	BLACK	20			
	3	COM	BLACK	20			
	4	+5V	RED	20			
P8	1	+5V	RED	22	AMP 171822-4 or EQUIV.	170 $\pm$ 10mm	
	2	COM	BLACK	22			
	3	COM	BLACK	22			
	4	+12V1	YELLOW	22			

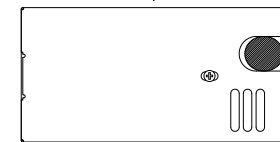

UPC barcode: 6LD02824XXGP  
BAR CODE LABEL

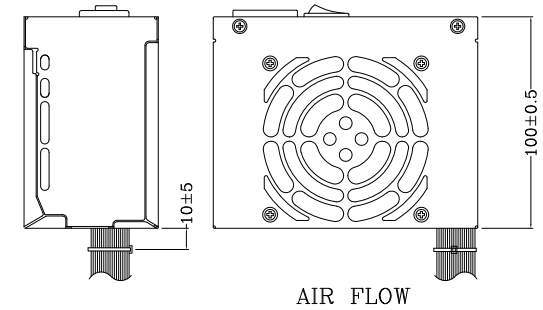
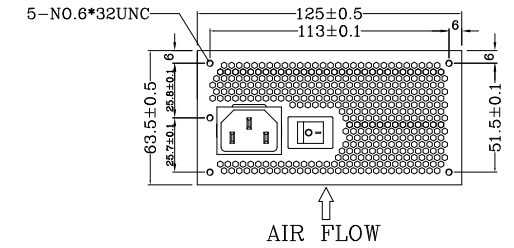
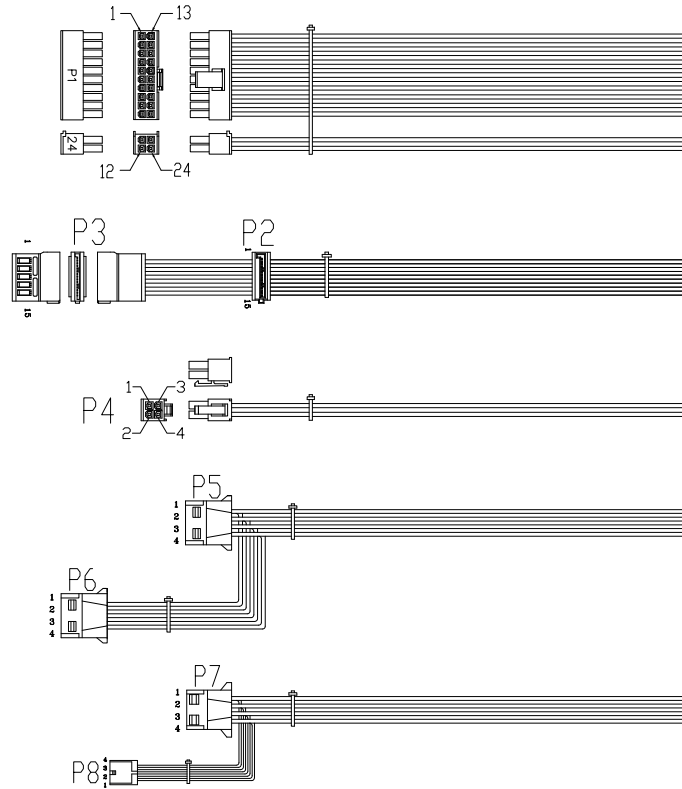
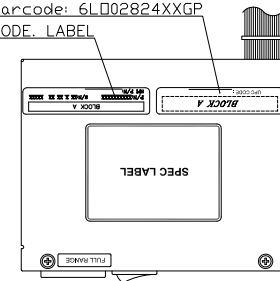

UNIT:mm

MODEL NO: TC-400PD8B-SFX		TITLE: ASSY			SHEET: 1 OF 1 REV:01	
R&D	PE	CHECKED	DESIGN	DRAWN	DATE	
				楊文	MAY.29.2013	