

TC-400PD8B-SFX

Switching Power Supply

(400W SFX ATX12V)

SPECIFICATION

Revision: 1.0

727. Phillips Drive City of Industry. CA 91748. USA
[http:// www.Xeal.com.tw](http://www.Xeal.com.tw)
TEL: 626-303-8885 FAX: 626-301-0588

1. GENERAL DESCRIPTION AND SCOPE

This is the specification of Model TC-400PD8B-SFX; AC-line powered switching power supply with active PFC (Power Factor Correction) circuit, meet EN61000-3-2 and with Full Range Input features. Also, +5Vsb power is less than $0.5W_{input}$ at power off mode (PS_ON input at high state) which is comply with ErP Lot 6 year 2013 requirement.

The specification below is intended to describe as detailedly as possible the functions and performance of the subject power supply. Any comment or additional requirements to this specification from our customers will be highly appreciated and treated as a new target for us to approach.

2. REFERENCE DOCUMENTS

The subject power supply will meet the EMI requirements and obtain main safety approvals as following:

2.1. EMI REGULATORY

FCC: FCC Part 15, Subpart B, Class B

-CISPR 22: 1997, Class B

-ICES-003: 2004, Class B

-ANSI C63.4-2003

EMC: EN55022: 2006+AI: 2007, Class B

EN 61000-3-2: 2007, Class D

EN 61000-3-3: 2008

CISPR 22: 2005+A1: 2005, Class B

AS/NZS CISPR 22: 2006, Class B

2.2. SAFETY

CB: IEC 60950~1:2005(2nd Edition) and/or EN 60950~1:2006 +A11:2009

UL: UL 60951-1 , 2nd Edition, 2007-03-27

TUV: EN 60950-1:2006+All

3. INPUT ELECTRICAL SPECIFICATIONS

3.1. AC INPUT

Parameter	Min.	Nom. ⁽¹⁾	Max.	Unit
V _{in} (115VAC)	90	115	135	VAC _{rms}
V _{in} (230VAC)	180	230	265	VAC _{rms}
V _{in} Frequency	47	--	63	HZ

◆ Nominal voltages for test purposes are considered to be within $\pm 1.0V$ of nominal.

3.2. INRUSH CURRENT

Maximum inrush current from power-on (with power on at any point on the AC sine) and including, but not limited to, three line cycles, shall be limited to a level below the surge rating of the input line cord, AC switch if present, bridge rectifier, fuse, and EMI filter components. Repetitive ON/OFF cycling of the AC input voltage should not damage the power supply or cause the input fuse to blow.

3.3. INPUT LINE CURRENT & POWER FACTOR (P.F.)

(At Full load)

AC input	Input line current	P.F.@ Full Load	P.F.@ Pin=75W
115V	< 4.5Amps – rms	> 0.95	> 0.8
230V	< 2.5Amps – rms	> 0.9	> 0.6

3.4. EFFICIENCY

3.4.1 General

Under the load conditions defined in Table 1 and Table 2. The loading condition for testing efficiency shown in Table 1 represents a fully loaded system. a ~ 50% (typical) loaded system. And a ~ 20% (light) loaded system.

Table 1. Loading Table for Efficiency Measurements

400W(loading shown in Amps)						
Loading	+12V1	+12V2	+5V	+3.3V	-12V	+5Vsb
Full	12.72	11.97	10.61	11.14	0.37	1.87
Typical	6.36	5.99	5.30	5.57	0.19	0.94
Light	2.54	2.39 2.	12	2.23	0.07	0.37

Table 2. Minimum Efficiency Vs Load

Loading	Voltage	Full load	Typical load	Light load
Required Minimum Efficiency	115V	82%	85%	82%
Required Minimum Efficiency	230V	82%	85%	82%

3.4.2 Standby Power Consumption (+5Vsb):

Input Power < 0.5W @ +5Vsb/45mA & 230Vac input

PS_ON input signal @ High State

4 . OUTPUT ELECTRICAL REQUIREMENTS**4.1. OUTPUT VOLTAGE AND CURRENT RATING**

Output	MINIMUM LOAD	NORMAL LOAD	MAXIMUM LOAD	PEAK LOAD	LOAD REG	LINE REG.	RIPPLE & NOISE
+3.3V	0.1A	10.5A	21A		±5%	±1%	70mV P-P
+5V	0.2A	11A	22A		±5%	±1%	70mV P-P
+12V1	0.1A	9A	17A		±5%	±1%	140mV P-P
+12V2	0.5A	9A	16A	19A	±5%	±1%	140mV P-P
-12V	0A	0.25A	0.5A		±10%	±1%	140mV P-P
+5VSB	0A	1.25A	2.5A	3.5A	±5%	±1%	70mV P-P

(1) +3.3V & 5V total output not exceed 120W.

(2) Total output continuous shall not exceed 400W watts.

(3) +12V2 Peak current is 19A(less then 10m Sec.), minimum voltage during peak is >10.8Vdc.

(4) 5Vsb Peak current is 3.5A(less then 500m Sec.), minimum voltage during peak is > 4.5Vdc.

Voltages and ripple are measured at the load side of mating connectors with a 0.1 uF monolithic ceramic capacitor paralleled by a 10 uF electrolytic capacitor across the measuring terminals.

4.2. LOAD CAPACITY SPECIFICATIONS

The cross regulation defined as follows, the voltage regulation limits DC include DC Output ripple & noise.

LOAD	+3.3V	+5V	+12V1	+12V2	-12V	+5VSB
Condition_1	X	X	X	X	X	2.5A
Condition_2	0.5A	0.5A	1A	1A	0A	0A
Condition_3	0.5A	0.5A	1A	1A	0.5A	0A
Condition_4	1 A	10A	1A	16A	0.1A	0.1A
Condition_5	1 A	2A	16A	1A	0.1A	0.1A
Condition_6	1 A	14A	2A	2A	0.1A	0.1A
Condition_7	4.5A	22A	11.5A	10A	0.5A	2A
Condition_8	18A	2A	1A	1A	0A	0.1A
Condition_9	20A	11.8A	11.5A	10A	0.5A	2A

4.3. HOLD-UP TIME (@Typical Load of Table. 1)

115V / 60Hz : 24 m Sec. Minimum.

230V / 50Hz : 24 m Sec. Minimum.

The output voltage will remain within specification, in the event that the input power is removed or interrupted, for the duration of one cycle of the input frequency. The interruption may occur at any point in the AC voltage cycle. The power good signal shall remain high during this test.

4.4.OUTPUT RISE TIME

(10% TO 90% OF FINAL OUTPUT VALUE, @FULL LOAD)

115V-rms or 230V-rms + 3.3Vdc : 20ms Maximum
 + 5Vdc : 20ms Maximum
 + 12Vdc : 20ms Maximum
 + 5Vsb : 20ms Maximum
 - 12Vdc : 20ms Maximum

4.5.OVER VOLTAGE PROTECTION

Voltage Source	Protection Point
+3.3V	3.76V-4.8V
+5V	5.6V-7.0V
+12V	13.0V-16.5V

4.6.OVER-CURRENT PROTECTION

OUTPUT VOLTAGE	Max. over current limit
+3.3V	60A
+5V	48A
+12V1	40A
+12V2	40A

4.7.SHORT CIRCUIT PROTECTION

Output short circuit is defined to be a short circuit load of less than 0.1 ohm.

In the event of an output short circuit condition on +3.3V, +5V, +12V or-12V output, the power supply will shutdown and latch off without damage to the power supply. The power supply shall return to normal operation after the short circuit has been removed and the power switch has been turned off for no more than 2 seconds.

4.8. POWER SIGNAL

POWER GOOD @ 115/230V, FULL LOAD	100 –500mSec.
POWER FAIL @115/230V, FULL LOAD	1 mSec. minimum

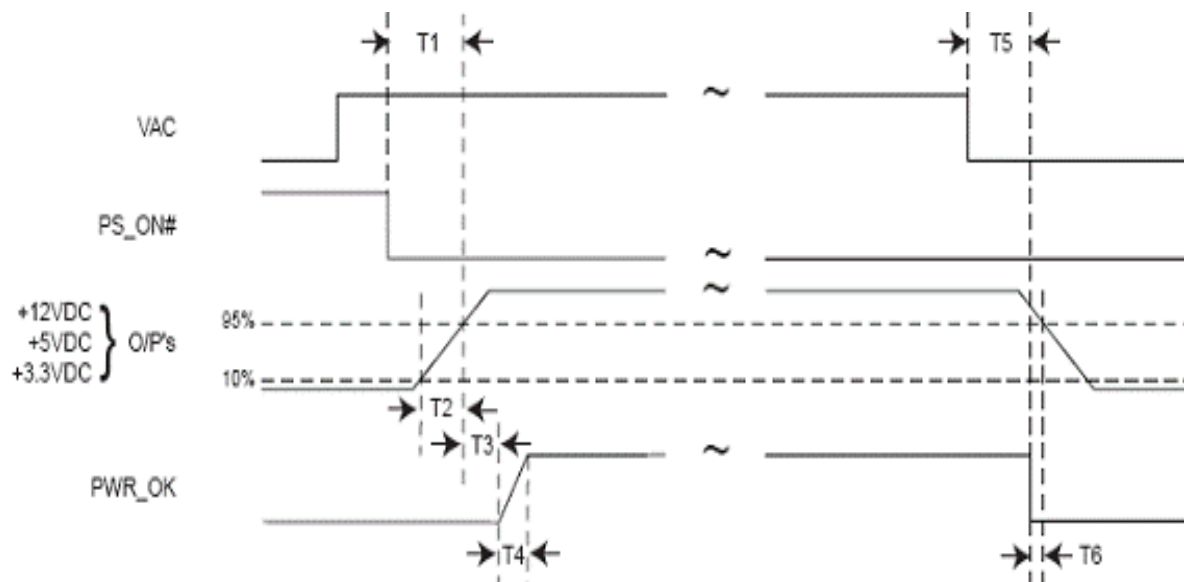

Figure:

T1: Power-on time shall be less than 500 ms ($T1 < 500$ ms).

T2: Rise time : 0.1 ms to 20 ms ($0.1 \text{ ms} \leq T2 \leq 20$ ms).

T3: Power-ok delay time: 100 ms < $T3 < 500$ ms

T4: Power-ok rise time: $T4 \leq 10$ ms

$T5 + T6$: AC loss to output hold-up time : $T5 + T6 \geq 17$ ms

- 4.9. The main power supply shall be off when the PS_ON pin is floating (open collector). The ON/STBY pin of P1 must remain off state for 5 Sec (maximum) prior to switching to the ON state.

5. FAN NOISE REQUIREMENTS

- 5.1. The subject power supply is cooled by a self-contained, 80mm×15mm, 12VDC fan.

6. ENVIRONMENTAL REQUIREMENTS

The power supply will be compliant with each item in this specification for the following Environmental conditions.

6.1. TEMPERATURE RANGE

Operating	+10 to +50 deg. C
Storage	-20 to +80 deg. C

6.2. HUMIDITY

Operating	5 –95% RH, Non-condensing
Storage	5 –95% RH, Non-condensing

6.3. VIBRATION

The subject power supply will withstand the following imposed conditions without experiencing non-recoverable failure or deviation from specified output characteristics.

Vibration Operating – Sine wave excited, 0.25 G maximum acceleration, 10-250 Hz swept at one octave / min. Fifteen minute dwell at all resonant points, where resonance is defined as those exciting frequencies at which the device under test experiences excursions two times large than non-resonant excursions.

Plane of vibration to be along three mutually perpendicular axes.

6.4. GROUND LEAKAGE CURRENT

The power supply ground leakage current shall be less than 3.5 mA.

6.5. RELIABILITY

The power supply reliability, when calculated by MIL-HDBK-217; latest revision, are exceed 100,000 hours with all output at Typical load and an ambient temperature of 25°C.

6.6. DIELECTRIC STRENGTH

Primary to Frame Ground : 1800 Vac for 1 sec.

Primary to Secondary : 1800Vac for 1 sec

6.7. INSULATION RESISTANCE

Primary to Frame Ground : 20 Meg.ohms Minimum

Primary to Secondary : 20 Meg.ohms Minimum

7. LABELLING

Label marking will be permanent, legible and complied with all agency requirements.

7.1. MODEL NUMBER LABEL

Labels will be affixed to the sides of the power supply showing the following:

- Manufacturer's name and logo.
- Model no., serial no., revision level, location of manufacturer.
- The total power output and the maximum load for each output.
- AC input rating.

8. MECHANICAL SPECIFICATIONS

The mechanical drawing of the subject power supply, which indicate the form factor, location of the mounting holes, location, the length of the connectors, and other physical specifications of the subject power supply. Please refer to the attachment drawing.